

Power Strobe 1500 DMX
stroboscope

Musikhaus Thomann
Thomann GmbH
Hans-Thomann-Straße 1
96138 Burgebrach
Germany
Telephone: +49 (0) 9546 9223-0
E-mail: info@thomann.de
Internet: www.thomann.de

22.02.2016, ID: 168875

Table of contents

1	General information	5
	1.1 Further information.....	6
	1.2 Notational conventions.....	7
	1.3 Symbols and signal words.....	7
2	Safety instructions	10
3	Features	15
4	Installation	16
5	Starting up	20
6	Connections and controls	22
7	Operating	26
8	Maintenance	29
9	Technical specifications	36
10	Plug and connection assignments	37
11	Troubleshooting	38

12	Cleaning.....	40
13	Protecting the environment.....	41

1 General information

This manual contains important instructions for the safe operation of the unit. Read and follow the safety instructions and all other instructions. Keep the manual for future reference. Make sure that it is available to all those using the device. If you sell the unit please make sure that the buyer also receives this manual.

Our products are subject to a process of continuous development. Thus, they are subject to change.

1.1 Further information

On our website (www.thomann.de) you will find lots of further information and details on the following points:

Download	This manual is also available as PDF file for you to download.
Keyword search	Use the search function in the electronic version to find the topics of interest for you quickly.
Online guides	Our online guides provide detailed information on technical basics and terms.
Personal consultation	For personal consultation please contact our technical hotline.
Service	If you have any problems with the device the customer service will gladly assist you.

1.2 Notational conventions

This manual uses the following notational conventions:

Letterings





The letterings for connectors and controls are marked by square brackets and italics.

Examples: *[VOLUME]* control, *[Mono]* button.

1.3 Symbols and signal words

In this section you will find an overview of the meaning of symbols and signal words that are used in this manual.

Signal word	Meaning
DANGER!	This combination of symbol and signal word indicates an immediate dangerous situation that will result in death or serious injury if it is not avoided.
WARNING!	This combination of symbol and signal word indicates a possible dangerous situation that can result in death or serious injury if it is not avoided.
CAUTION!	This combination of symbol and signal word indicates a possible dangerous situation that can result in minor injury if it is not avoided.
NOTICE!	This combination of symbol and signal word indicates a possible dangerous situation that can result in material and environmental damage if it is not avoided.
Warning signs	Type of danger
	Warning – high-voltage.

Warning signs	Type of danger
	Warning – hot surface.
	Warning – dangerous optical radiation.
	Warning – suspended load.
	Warning – toxic substances.
	Warning – danger zone.

2 Safety instructions

Intended use

This device is intended to be used as an illumination effect. The device is designed for professional use and is not suitable for use in households. Use the device only as described in this user manual. Any other use or use under other operating conditions is considered to be improper and may result in personal injury or property damage. No liability will be assumed for damages resulting from improper use.

This device may be used only by persons with sufficient physical, sensorial, and intellectual abilities and having corresponding knowledge and experience. Other persons may use this device only if they are supervised or instructed by a person who is responsible for their safety.

Safety



DANGER!

Danger for children

Ensure that plastic bags, packaging, etc. are disposed of properly and are not within reach of babies and young children. Choking hazard!

Ensure that children do not detach any small parts (e.g. knobs or the like) from the unit. They could swallow the pieces and choke!

Never let children unattended use electrical devices.



DANGER!

Electric shock caused by high voltages inside

Within the device there are areas where high voltages may be present. Never remove any covers.

There are no user-serviceable parts inside.



DANGER!

Electric shock caused by short-circuit

Do not modify the mains cable or the plug. Failure to do so could result in electric shock/death or fire. If in doubt, seek advice from a registered electrician.



WARNING!

Eye damage caused by high light intensity

Never look directly into the light source.



WARNING!

Risk of epileptic shock

Strobe lighting can trigger seizures in photosensitive epilepsy. Sensitive persons should avoid looking at strobe lights.



NOTICE!

Risk of fire

Do not cover the device nor any ventilation slots. Do not place the device near any direct heat source. Keep the device away from naked flames.



NOTICE!

Operating conditions

This device has been designed for indoor use only. To prevent damage, never expose the device to any liquid or moisture. Avoid direct sunlight, heavy dirt, and strong vibrations.



NOTICE!

Power supply

Before connecting the device, ensure that the input voltage (AC outlet) matches the voltage rating of the device and that the AC outlet is protected by a residual current circuit breaker. Failure to do so could result in damage to the device and possibly injure the user.

Unplug the device before electrical storms occur and when it is unused for long periods of time to reduce the risk of electric shock or fire.

3 Features

- powerful Stroboscope effect
- flash light energy: 1500 W
- strobe frequency steplessly adjustable
- brightness steplessly adjustable
- control via DMX or optional remote
- Operating modes: Master/Slave, DMX
- DMX address and operating mode adjustable via DIP switches
- illuminant included

4 Installation

Unpack and carefully check that there is no transportation damage before using the unit. Keep the equipment packaging. To fully protect the device against vibration, dust and moisture during transportation or storage use the original packaging or your own packaging material suitable for transport or storage, respectively.



WARNING!

Risk of injury caused by falling objects

Make sure that the installation complies with the standards and rules that apply in your country. Always secure the device with a secondary safety attachment, such as a safety cable or a safety chain.



NOTICE!

Risk of overheating

Always ensure sufficient ventilation.

The ambient temperature must always be below 40 °C (104 °F).



NOTICE!

Use of stands

When mounting the device onto a stand, ensure that the stand is in a safe and stable position and that the weight of the device does not exceed the maximum permissible load capacity of the stand.



NOTICE!

Possible data transmission errors

For error-free operation make use of dedicated DMX cables and do not use ordinary microphone cables.

Never connect the DMX input or output to audio devices such as mixers or amplifiers.

Mounting options

You can install the unit in hanging or standing position. When in use, the device must always be attached to a solid surface or an approved truss. Use the opening of the bracket provided for mounting.

Always work from a stable platform whenever installing, moving or servicing the unit. In doing so, the area underneath the unit must be cordoned off.

The safety-rope must be attached to the bracket.



Please note that this device must not be connected to a dimmer.

5 Starting up

Establish all connections as long as the unit is switched off. Use the shortest possible high-quality cables for all connections.

Connections in DMX mode

Connect the DMX input of the device to the DMX output of a DMX controller or another DMX device. Connect the output of the first DMX device to the input of the second one, and so on to form a daisy chain. Always ensure that the output of the last DMX device in the daisy chain is terminated with a resistor ($110\ \Omega$, $\frac{1}{4}\ \text{W}$).

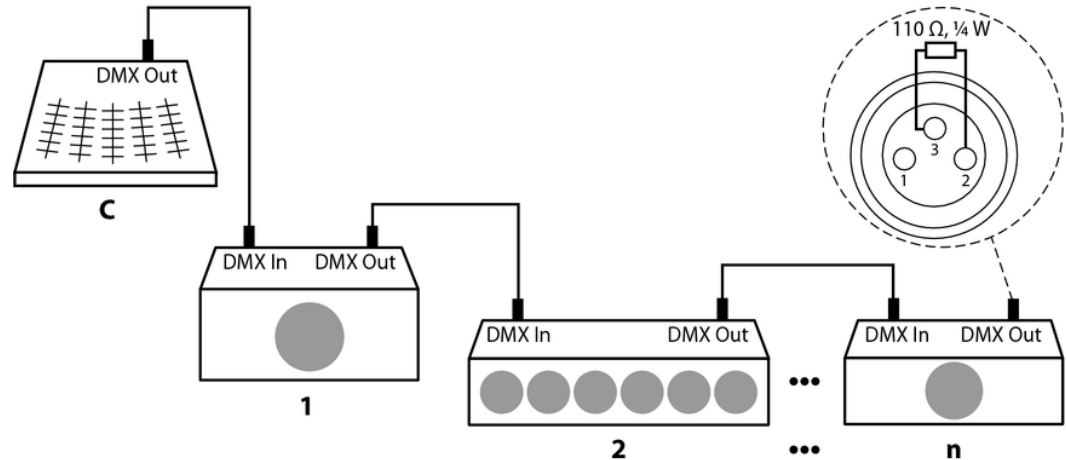

6 Connections and controls

Front panel

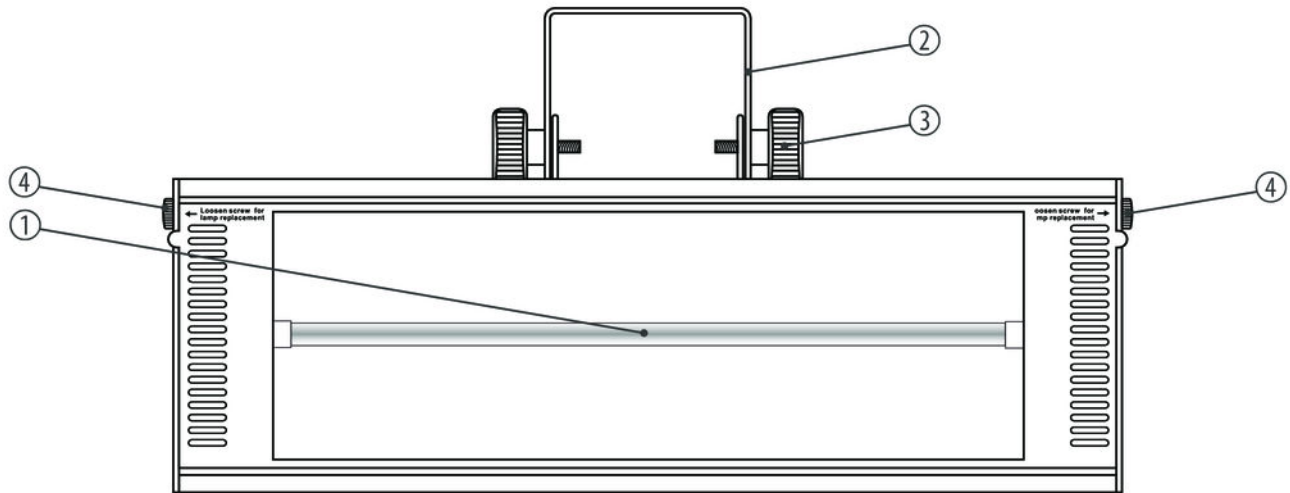

- | | |
|---|--|
| 1 | Illuminant. |
| 2 | Mounting bracket. |
| 3 | Locking screws for the mounting bracket. |
| 4 | Knurled screw to open the front cover. |

Control panel and connections

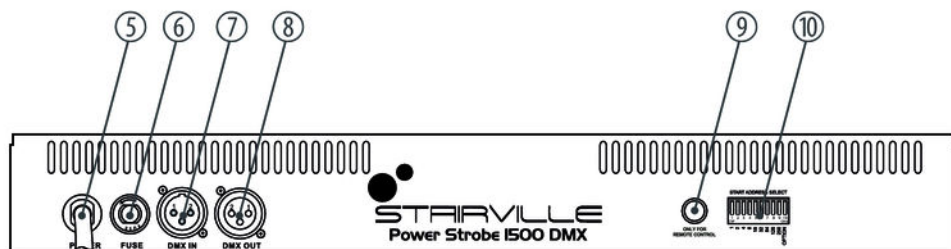

5	<i>[POWER]</i> Mains cable for power supply.
6	Resettable 15 A fuse.
7	<i>[DMX IN]</i> DMX input.
8	<i>[DMX OUT]</i> DMX output.
9	<i>[ONLY FOR REMOTE CONTROL]</i> 1/4" phone socket to connect an optionally available remote control.
10	<i>[START ADDRESS SELECT]</i> DIP switch for setting the DMX address.

7 Operating

Starting the device

To start up the device, connect it to the mains. The device is immediately ready for operation.

Operating mode 'Master / Slave'

This setting is only relevant if the device is working as Slave in a Master / Slave configuration and is not controlled via DMX. In this operating mode, the device responds to the control signals of the master device.

Establish all necessary connections and set DIP switch no. 10 to *[ON]*, all others to *[OFF]* to enable the mode.

Operating mode 'Sound to Light'

This setting is only relevant if the device is working in Stand Alone mode and is not controlled via DMX.

To enable the sound-controlled mode, set all DIP switches to *[ON]*.

Operating mode 'DMX'

This setting is only relevant when the device is controlled via DMX.

Use the DIP switches of the device to set the desired DMX address between 1 and 512 (see the following figure).

DMX Address Set

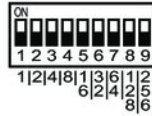

DMX Add 001



DMX Add 002



DMX Add 003



DMX Add 004



DMX Add 005

.....



DMX Add 512

DMX channel allocation

Channel	Value	Function
1	Strobe frequency	
	0 ... 15	not lit
	16 ... 255	Level 1 (1 flash per second) ... level 15 (12 flashes per second)
2	Brightness	
	0 ... 15	Blackout
	16 ... 255	Level 1 ... level 15

Resettable 15 A fuse.

After the fuse has tripped, press the fuse button in the control panel of the device.

If the 15 A fuse trips repeatedly within a short time or can not be reset, the device must be checked and repaired by a qualified electrician.

8 Maintenance



DANGER!

Electric shock caused by high voltages inside

Within the device there are areas where high voltages may be present.

Completely disconnect the device from the power supply before you open or remove covers. Mount all covers and attach them firmly before connecting the device again.



WARNING!

Risk of burns at the surface and inside of the device

The surface and the inner parts of the device can become very hot during operation.

After switching off the device wait for at least 15 minutes before you start any maintenance activities.



WARNING!

Danger of burns in case of inappropriate handling of the illuminant

The light source used in this device is under high pressure, especially when heated, and can explode if handled inappropriately.

Allow the illuminant to cool down for at least two hours before starting any maintenance or replacement. Always wear suitable protective gloves and safety glasses when handling the illuminant.



WARNING!

Danger of poisoning on lamp breakage

When discharge lamps break, small amounts of harmful substances (e.g. mercury) are released.

When a discharge lamp breaks within a closed room: Vacate the room immediately and ventilate adequately.

To remove the remnants of broken discharge lamps wear Nitrile protective gloves, breathing and mouth protection.

Dispose of broken or worn discharge lamps as hazardous waste according to legal regulations in a tightly closed container.



WARNING!

Danger of burns and eye injuries caused by high light intensity

The light source used in this device produces visible and invisible light beams of high intensity.

Never look directly into the light source.

Do not use the device when covers, shieldings, lenses or other optical components are missing or damaged. In particular, avoid prolonged direct exposure of the skin during maintenance without adequate cover of the light source.



CAUTION!

Danger of injury in case of inappropriate handling of the illuminant

After the specified lifetime of the used illuminant there is an increased risk of explosion.

Replace the illuminant in time, latest at the end of rated average lifetime.

When replacing the illuminant, all safety instructions for handling light sources must be observed and wear suitable protective gloves and safety glasses.

**NOTICE!****Possible damages due to dirt or finger prints**

Due to the high temperatures, even smallest pieces of dirt on the bulb can destroy the lamp when it is turned on.

Do not touch the lamp directly with your fingers. Use clean gloves or a clean lint-free tissue.

**NOTICE!****Possible damages due to wrong type of lamp**

Any attempt to use the device with a lamp other than those specified in this manual can result in severe damages to the device.

Only use a lamp of the specified type.

Notes on the illuminant

The device must only be operated with an illuminant type xenon 1500. Observe the safety instructions of the illuminant manufacturer.

Procedure

1. Make sure that the device is turned off, disconnected from the mains and completely cooled down.
2. Place the device on a clean, flat work surface.

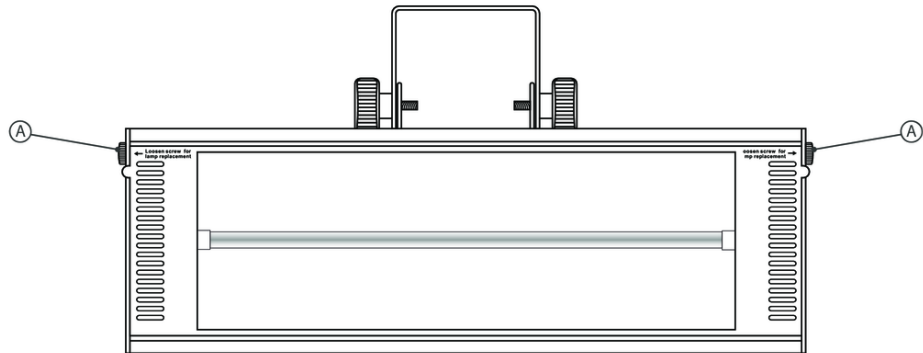

3. Unscrew the two knurled screws (A) right and left on the housing completely and open up the front cover forward.

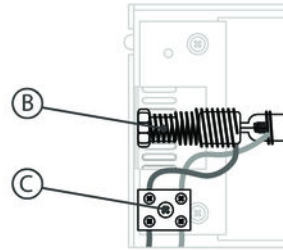

- 4.** ▶ Use a suitable screwdriver to loosen the cable connections (C) of the illuminant.
- 5.** ▶ Pull the retaining springs (B) as far back that you can remove the illuminant.

Installation of the new illuminant is done in reverse order. Only reconnect the device to the power grid after the front cover has been closed and securely fixed with the two knurled screws.

9 Technical specifications

Number of DMX channels	2
Strobe frequency	steplessly adjustable from 1 ... 12 flashes per second
Brightness	steplessly adjustable from 0 ... 100 %
Power consumption	approx. 1600 W
Operating supply voltage	AC 230 V ~ 50 Hz
Fuse	resettable, 15 A
Dimensions (W × H × D)	453 mm × 145 mm × 115 mm
Weight	2.9 kg

10 Plug and connection assignments

Introduction

This chapter will help you select the right cables and plugs to connect your valuable equipment so that a perfect light experience is guaranteed.

Please take our tips, because especially in 'Sound & Light' caution is indicated: Even if a plug fits into a socket, the result of an incorrect connection may be a destroyed DMX controller, a short circuit or 'just' a not working light show!

DMX connections

The unit offers a 3-pin XLR socket for DMX output and a 3-pin XLR plug for DMX input. Please refer to the drawing and table below for the pin assignment of a suitable XLR plug.



Pin	Configuration
1	Ground, shielding
2	Signal inverted (DMX-, 'cold signal')
3	Signal (DMX+, 'hot signal')

11 Troubleshooting



NOTICE!

Possible data transmission errors

For error-free operation make use of dedicated DMX cables and do not use ordinary microphone cables.

Never connect the DMX input or output to audio devices such as mixers or amplifiers.

In the following we list a few common problems that may occur during operation. We give you some suggestions for easy troubleshooting:

Symptom	Remedy
The unit does not work, no light	<ol style="list-style-type: none"> 1. Check the mains connection and the main fuse. 2. Check the position of each DIP switch.
No response to the DMX controller	<ol style="list-style-type: none"> 1. Check whether the DMX cables run near or parallel to high-voltage cables that may cause damage or interference to a DMX interface circuit. 2. Check the position of each DIP switch. 3. Try using another DMX controller.

If the procedures recommended above do not succeed, please contact our Service Center. You can find the contact information at www.thomann.de.

12 Cleaning

Device components

Clean the device components that are accessible from the outside regularly. The cleaning frequency depends on the operating environment: damp, smoky or particularly dirty environments can cause greater accumulation of dirt on the device components.

- Clean with a dry soft cloth.
- Stubborn dirt can be removed with a slightly dampened cloth.
- Never use solvents or alcohol for cleaning.

Fan grids

The fan grids of the device must be cleaned on a regular basis to remove dust and dirt. Before cleaning, switch off the device and disconnect AC-powered devices from the mains. Use a lint-free damp cloth for cleaning. Never use solvents or alcohol for cleaning.

13 Protecting the environment

Disposal of the packaging material



For the packaging, environmentally friendly materials have been chosen that can be supplied to normal recycling.

Ensure that plastic bags, packaging, etc. are properly disposed of.

Do not just dispose of these materials with your normal household waste, but make sure that they are collected for recycling. Please follow the notes and markings on the packaging.

Disposal of your old device



This product is subject to the European Waste Electrical and Electronic Equipment Directive (WEEE) in its currently valid version. Do not dispose with your normal household waste.

Dispose of this device through an approved waste disposal firm or through your local waste facility. When discarding the device, comply with the rules and regulations that apply in your country. If in doubt, consult your local waste disposal facility.

Dispose of discharge lamps

Dispose of broken or worn discharge lamps as hazardous waste according to legal regulations in a tightly closed container.



Musikhaus Thomann · Hans-Thomann-Straße 1 · 96138 Burgebrach · Germany · www.thomann.de