

# JEM ZR44 HI-MASS™

## user manual



# Dimensions

All dimensions are in millimeters

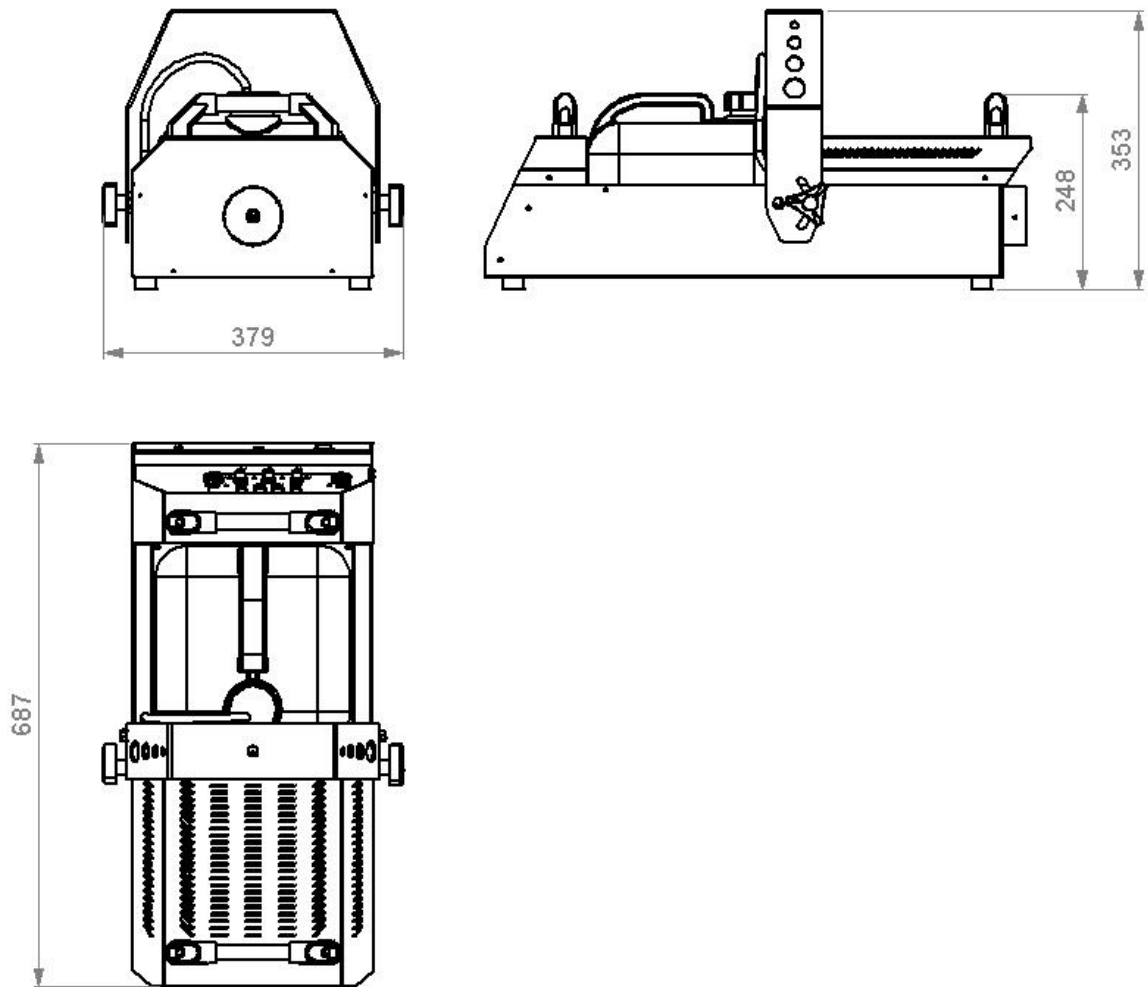

---

© 2016 Martin Professional™ ApS. Information subject to change without notice. Martin Professional™ and all affiliated companies disclaim liability for any injury, damage, direct or indirect loss, consequential or economic loss or any other loss occasioned by the use of, inability to use or reliance on the information contained in this manual. Martin™, Harman™ and all other trademarks in this document pertaining to services or products by Martin Professional™ or its affiliates and subsidiaries are registered as the property of Harman International Industries.

---

# Contents

|   |    |
|---|----|
| Dimensions .....                            | 2  |
| Contents .....                              | 3  |
| Safety information.....                     | 4  |
| Product overview .....                      | 7  |
| Product description.....                    | 7  |
| Features at a glance .....                  | 7  |
| Product details .....                       | 8  |
| Quick Start .....                           | 9  |
| Setting up.....                             | 9  |
| Making fog .....                            | 9  |
| Installation and setting up .....           | 10 |
| Location .....                              | 10 |
| AC power .....                              | 10 |
| Setting up.....                             | 11 |
| Final checks .....                          | 11 |
| Turning on the power.....                   | 11 |
| Control settings .....                      | 12 |
| Overview .....                              | 12 |
| Manual firing .....                         | 12 |
| Setting fog output level .....              | 12 |
| Setting the Timer.....                      | 12 |
| Setting the master-slave link mode.....     | 12 |
| Digital remote control .....                | 13 |
| Overview .....                              | 13 |
| Functions .....                             | 13 |
| DMX control .....                           | 14 |
| Overview .....                              | 14 |
| Connection.....                             | 14 |
| DMX functions.....                          | 14 |
| Setting the DMX address .....               | 15 |
| Approved fluid types.....                   | 16 |
| Pro Clean Supreme Fluid.....                | 17 |
| Basic service.....                          | 18 |
| Cleaning.....                               | 18 |
| Fuse replacement .....                      | 18 |
| Troubleshooting .....                       | 19 |
| Resetting the machine after fluid out ..... | 19 |
| Technical Specifications .....              | 20 |
| Notes .....                                 | 24 |

# Safety information

The following symbols are used to identify important safety information:



Caution! Safety hazard. Risk of personal injury.



Caution! Burn hazard. Hot surface. Do not touch.



Danger! Hazardous voltage. Contact will cause electric shock.



Caution! Fire hazard.



Warning! This product is not for household use. It presents risks of injury due to electric shock, burns, falls and respiratory problems!

Read this manual before operating the machine, follow the safety precautions listed below, and observe all warnings in this manual and printed on the machine. Use the system only as described in this manual and in accordance with local laws and regulations.

If you have questions about how to operate the machine safely, or if you have followed the instructions in this manual and the machine is malfunctioning, please contact Martin Service.

## Preventing electric shocks



- Always ground (earth) the machine electrically.
- Use only a source of AC power that complies with local building and electrical codes, and that has both overload and ground-fault protection.
- Before connecting the fog machine to power, check that the voltage indicated on the machine's serial label matches your local AC power voltage. If your AC power voltage does not match, do not use the machine. Contact Martin Service for assistance.
- Before using the machine, check that all power distribution equipment and cables are in perfect condition and rated for the current requirements of all connected devices.
- If the machine or any cables connected to it are in any way damaged, defective, wet, or show signs of overheating, stop using the machine and contact Martin Service for assistance. If the supply cord is damaged, it must be replaced by a special cord or assembly available from the manufacturer or its service agent.
- Disconnect the machine from AC power before servicing and when not in use.
- This system is not waterproof and should not be exposed to wet outdoor conditions. Do not immerse in water or any other liquid. Do not expose to high-pressure water jets.
- Do not spill fluid over or inside the machine. If fluid is spilled, disconnect AC power and clean with a damp cloth. If fluid is spilled onto electronic parts, take the system out of service and contact Martin for advice.

- Do not remove the covers or attempt to repair a faulty machine. Refer any service not described in this manual to Martin.
- Do not operate the machine if any parts are damaged, defective or missing.
- Moisture and electricity do not mix. Do not aim fog output at electrical connections or devices.

### Preventing burns and fire



- The fog produced by the machine is hot enough to cause burns when it leaves the nozzle, and very hot droplets of fluid escape occasionally. Keep people and objects at least 1 meter (39 inches) away from the fog output nozzle.
- Do not touch the fog output nozzle during or after use – it becomes extremely hot and remains hot for several hours after the machine has been shut down.
- Fog output contains glycol, a flammable alcohol that burns with an almost invisible blue flame. Do not point fog output at sources of ignition such as open flames or pyrotechnic effects.
- Do not attempt to bypass thermostatic switches, fluid sensors or fuses.
- Replace fuses only with ones of the type and rating specified in this manual for the machine.
- Provide a minimum free space of 100 mm (4 in.) around the machine.
- Provide a minimum free space of 500 mm (20 in.) around fans and air vents and ensure free and unobstructed air flow to and around the machine.
- Keep the machine at least 600 mm (24 in.) away from combustible and heat-sensitive materials.
- Do not operate the machine if the ambient temperature ( $T_a$ ) is below 5° C (41° F) or above 40° C (104° F).
- Do not operate the machine if the relative air humidity exceeds 80%.

### Preventing injuries



- Ensure that the surface on which the machine is located or installed can safely hold the weight of the machine.
- Do not install the machine over areas where people are present.
- This appliance is not intended for use by persons (including children) with reduced physical sensory or mental capabilities, or lack of experience and knowledge, unless they have been given supervision or instruction concerning use of the appliance by a person responsible for their safety. Children should be supervised to ensure that they do not play with the appliance.
- Fog machines can cause condensation. Do not point the output at smooth floors. Floors and surfaces may become slippery. Check these frequently and wipe dry as necessary to avoid any danger of slipping.
- Ensure at least 2 m (6.6 ft.) visibility in areas where fog is being produced.
- Fog fluid contains food-grade glycols in solution but may present health risks if swallowed. Do not drink it. Store it securely. If eye contact occurs, rinse with water. If fluid is swallowed, give water and obtain medical advice.

## Preventing breathing problems



- A fog machine can operate safely only with the fog fluid it is designed for. Use the machine only with fluids specified under “Approved fluid types” on page 16 or you may cause the release of toxic gases, presenting a severe health hazard. You will also probably damage the machine.
- Do not create dense fog in confined or poorly ventilated areas.
- Do not expose people with health problems (including allergic and/or respiratory conditions such as asthma) to fog output.
- Do not point fog output directly at a person’s face or at face height.

# Product overview

## Product description

The JEM ZR44 Hi-Mass™ is a reliable and highly efficient fogger capable of precise fog delivery from subtle to massive. Ideal for a variety of settings from small venues to huge stadiums and arenas, it features advanced technology for top-quality performance, as well as advances in digital functionality such as RDM compatibility.

Following on from its predecessor the industry standard JEM ZR33™ the new JEM ZR44 Hi-Mass™ encompasses what Martin fog effect machines are all about: state of the art technology, high quality and ruggedness.

Congratulations on your purchase of this fog machine from Martin. Details of the full range of Martin products are available on our website at [www.martin.com](http://www.martin.com).

## Features at a glance

- Robust road-worthy design
- Integrated analog remote control
- DMX with RDM standard
- Hanging bracket included
- Continuous microprocessor controlled effect output
- Different fluid options for different applications
- 1800 W Heat exchanger
- Soft start technology
- Fluid sensing system
- Optional drip tray, digital remote control and ducting kit

## Product details

Remove remote control to access Digital remote (accessory) socket.

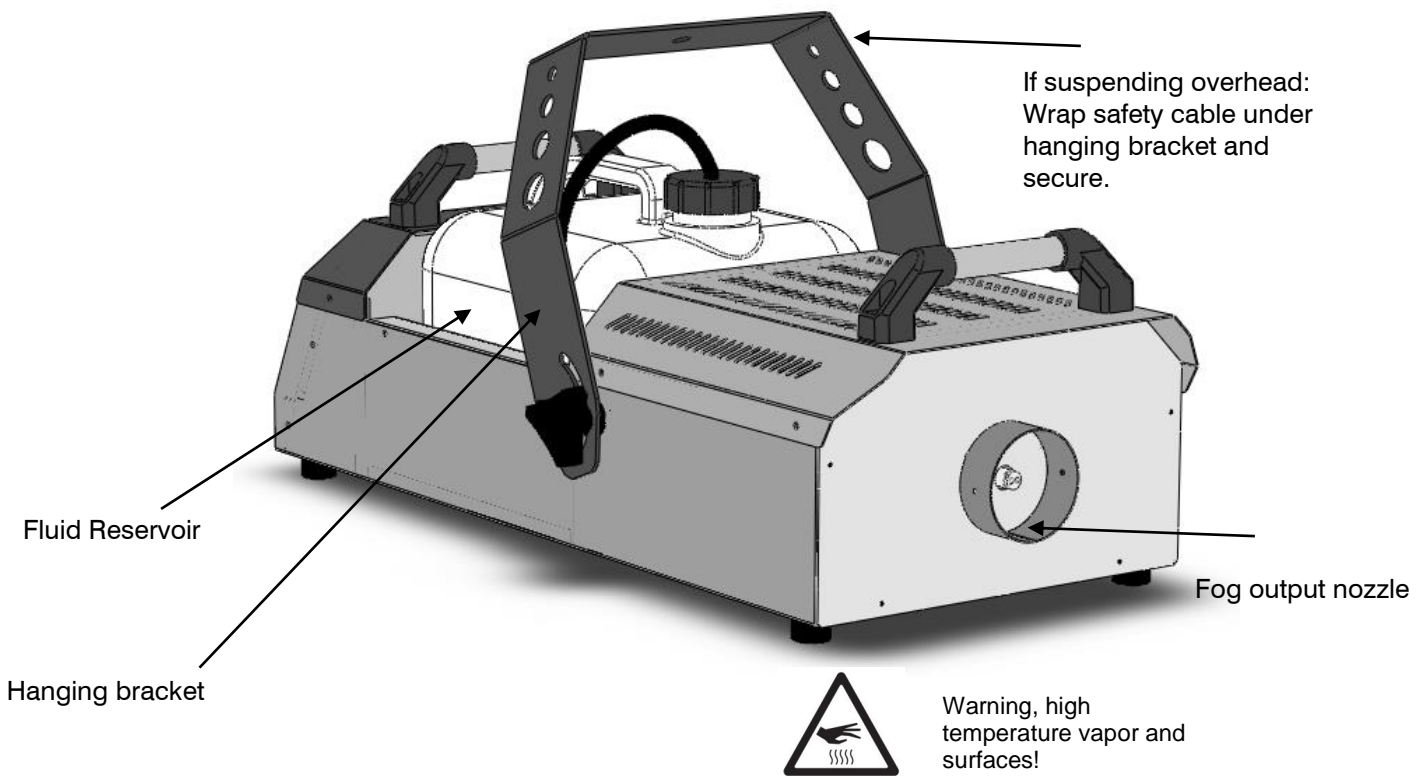
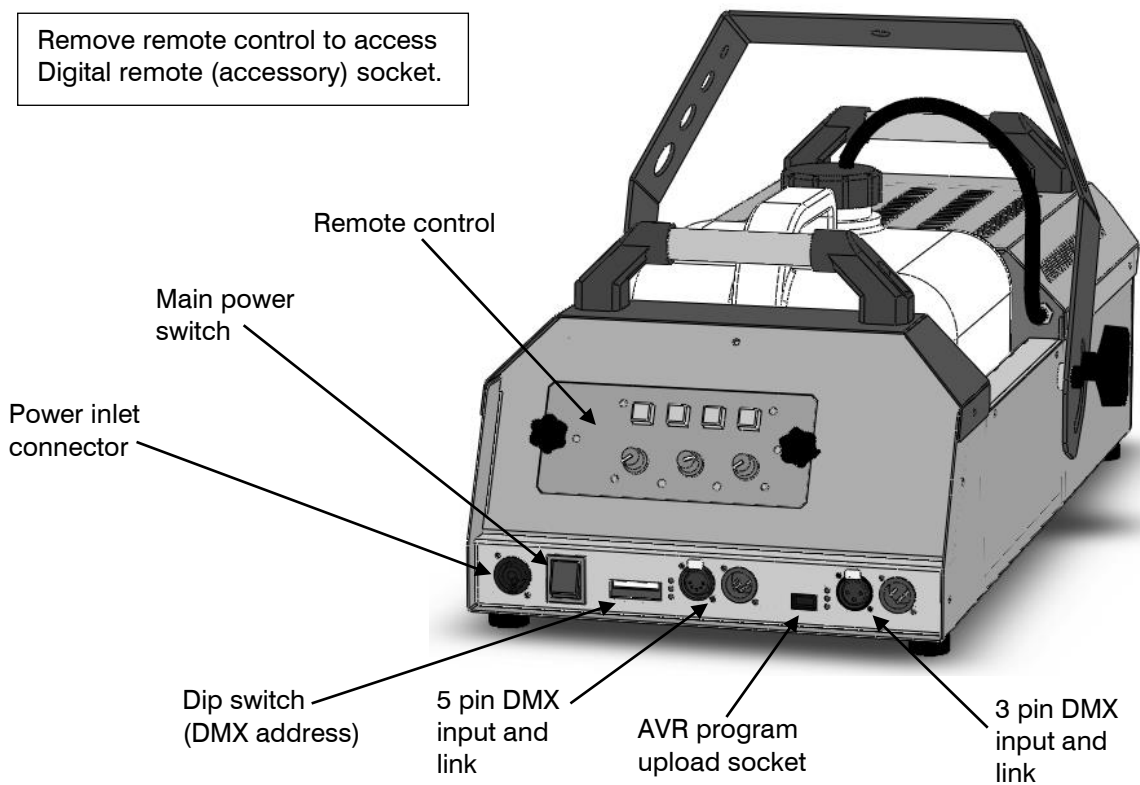



# Quick Start

You are no doubt eager to switch on the machine and try it out by making a lot of fog. This section tells you how to do that. However, please also make the time to read the safety and servicing instructions in the remainder of this manual.

## Setting up

Locate the machine in a suitably large area with nothing in front of the fog output.

Fill the fluid tank with Martin approved fluid (see page 16).

Connect the machine to a suitably rated power source. The power requirements are:

EU Models - 1890 W, 220-240 V

US Models – 1890 W, 100-130 V

Now set the mains switch, at the rear of the machine, to the 'ON' position and press the grey "stand-by" button.

The 'Ready' LED will flash indicating the machine is heating up; allow around 10 minutes for the machine to reach operating temperature. Once the machine has heated the 'Ready' LED will stop flashing and be permanently on.

## Making fog

Once the machine has heated up, hold the FOG button on the remote to start the fog output.

It may be necessary to prime the machine, to do this simply hold down the FOG button and turn the output knob to maximum. Keep the button held until the fog output is strong and steady. Then turn the knob back to the required output level and release the FOG button.

You can set the fog density by turning the knob. If the knob is turned fully counter-clockwise, no fog will be produced.

# Installation and setting up



**DANGER!** DO NOT operate the fog machine until you have read and observed all the precautions listed under “Safety information” on page 4.

## Location

The fog machine may be located on the floor or may be suspended using the hanging bracket. If suspending the machine, a standard hanging clamp (available from Martin) should be attached to the machines hanging bracket with an M12 bolt and nyloc nut. Additionally, a secondary backup device, a safety cable (available from Martin) should be looped around the hanging bracket.

The machine can operate in any orientation from 45 degrees upwards to 45 degrees downwards. Steeper tilting may cause fluid leakage.

If the machine is to be suspended, ensure the mounting surface can support the weight of the machine. Do not suspend the machine over areas where people will be underneath.

Ensure that there is at least 100 mm (4 in.) clearance around the machine and at least 600 mm (24 in.) in front of the fog output.

## AC power

Before using the machine, ensure that a grounding-type (earthed) power plug that fits the local power outlets is installed on the power cable.



**DANGER!** Make sure the power plug is correctly rated:

- For EU models use a plug rated at 10 A minimum
- For US models use a plug rated at 20 A minimum

When installing the plug, follow the plug manufacturer's instructions and connect pins as follows:

Yellow and green wire to ground (earth), blue wire to neutral and brown wire to live.

The table below shows some common pin identification schemes.

| wire         | function | marking | screw colour    |
|--------------|----------|---------|-----------------|
| brown        | live     | “L”     | yellow or brass |
| blue         | neutral  | “N”     | silver          |
| green/yellow | earth    |         | green           |

Before connecting the fog machine to power, verify that the AC supply is adequately dimensioned for the current draw of the machine. The machine requires:

EU Models - 1890 W, 220-240 V

US Models – 1890 W, 100-130 V

Check that the local AC voltage is appropriate, as indicated on the machine's serial number label. If your AC voltage is outside the appropriate range, do not use the machine. Contact Martin Service for assistance.

## Setting up

Fill the fluid tank with Martin approved fog fluid (see page 16).

If DMX control is being used, connect the machine to the DMX line (see page 14).

## Final checks

Before applying power to the fog machine, verify the following:

- the machine is safely located or installed and meets the location requirements stated on page 10
- the operator is familiar with, and able to comply with, the requirements for safe operation listed on page 4
- the fog fluid is one of the genuine Martin fluids listed under "Approved fluid types" on page 16
- the machine is electrically grounded (earthed)
- the AC power distribution circuits and lines are adequately rated for the current load

## Turning on the power

Turn on the main power switch located next to the power cable inlet. The green 'Ready' indicator on the rear of the machine will flash for about 10 minutes as the machine heats up to operating temperature.

When the green Ready indicator stops flashing and is permanently on, the machine is ready to make fog.

# Control settings

## Overview

The unit is controlled using the remote control. You can control it in these ways:

- Manual firing by holding down the FOG button
- Automatic fog bursts using a repeating timer

## Manual firing

Hold down the FOG button. The machine will produce fog until you release the button.

If a long burst of fog is produced, after a time the fog output level will be automatically reduced to keep the machine temperature within the operating range. This allows continuous operation, so that the machine does not have to stop and re-heat.

## Setting fog output level

Set the knob to the desired output level while firing the machine. The fog output level is always set by the current position of the knob, whether manually firing or in timer mode.

## Setting the Timer

**FOG BUTTON:** Will when the machine has reached operating temperature fire the machine when pressed and held.

**STAND-BY BUTTON:** This turns the machines electronics on and off.

**TIMER VALUE BUTTON:** When the timer is being used, the timer values can be adjusted by a factor of 8, i.e. a 5 second minimum run time becomes 40 seconds & a 10 second delay time becomes 1 minute 20 seconds.

**TIMER ENGAGE:** This will engage the timer to fire the machine according to the present settings.

**OUTPUT CONTROL:** Turning this knob clockwise will increase the output of the machine, if turned fully anti-clockwise there will be no output.

**DELAY TIME CONTROL:** This will adjust the amount of time the machine waits between operating when the timer is engaged.

**RUN TIME CONTROL:** This will adjust the time the machine will operate for when the timer is engaged.

**POWER LED:** This LED will light when the machine is switched on

**CYCLE LED:** This LED will light when the timer is engaged and the machine is operating.

## Setting the master-slave link mode

It is possible to control several machines from either the onboard remote control or the optional accessory digital remote. The machines are interconnected with DMX cabling via either the 3 or 5-pin XLR sockets situated on the rear of the machine

Dip switch 11 located on the rear of the machine must be set to the down position on the master unit.

# Digital remote control

## Overview

A Digital Remote control, available separately, may be used for control of the JEM ZR44 HI-MASS™

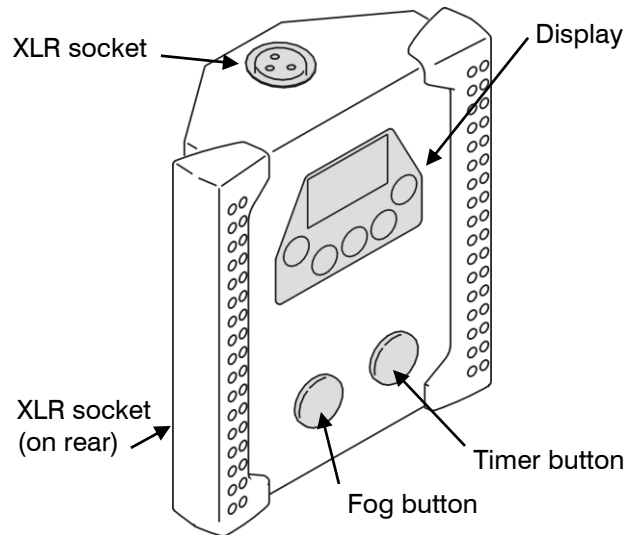

## Functions

The remote control provides the following functions:

- Fog button: turns fog output on and off. Press once to start fog and again to stop.
- Timer button: turns the fog timer on and off.
- Fog level setting (Fog = 0 -100%)
- Timer run time/off time settings (*TRUN*, *TOFF* = 0 - 90 seconds)
- Run mode (RUN = *OFF*, *STBY*, *TIME*, *CONT*)

The Fog button works by setting RUN to *CONT* (or *STBY*). The Timer button sets RUN to *TIME* or *STBY*. These buttons are simply a quick way to control this menu function.

# DMX control

## Overview

DMX is a digital control system widely used in entertainment and architectural lighting. Any controller meeting the DMX-512 standard may be used to control and program the fog output of the fog machine.

## Connection

The fog machine provides both 3 & 5-pin XLR plug and socket on the rear panel for DMX connection. The wiring is shown below.

| Connector pin | function        |
|---------------|-----------------|
| 1             | Ground          |
| 2             | Data – (“Cold”) |
| 3             | Data + (“Hot”)  |

For best results, use cable designed for high speed digital data transmission.

## DMX functions

The fog machine operates from a single DMX channel which gives proportional control of fog density from 0-100%.

| DMX Level | function   |
|-----------|--|
| 0 – 12    | No fog   |
| 13 – 255  | Fog at variable density, (13=minimum, 255=maximum) |

When the machine is receiving valid DMX data, the indicator light next to the address switches will light.

## Setting the DMX address

Each unit on a DMX system must be allocated an address so that the DMX controller can send separate commands to the unit. On the fog machine, the DMX address is set using the bank of switches (“dip switches”) on the back panel next to the DMX connectors. The switch settings for each possible DMX address are given in the table below.

| DIP-Switch Setting<br><br>0 = OFF<br>1 = ON |    |    |    |    | #9 | 0  | 0  | 0   | 0   | 0   | 0   | 0   | 0   | 1   | 1   | 1   | 1   | 1   | 1   | 1   | 1 |   |   |
|---|----|----|----|----|----|----|----|-----|-----|-----|-----|-----|-----|-----|-----|-----|-----|-----|-----|-----|---|---|---|
|   |    |    |    |    | #8 | 0  | 0  | 0   | 0   | 1   | 1   | 1   | 1   | 0   | 0   | 0   | 0   | 1   | 1   | 1   | 1 | 1 | 1 |
|   |    |    |    |    | #7 | 0  | 0  | 1   | 1   | 0   | 0   | 1   | 1   | 0   | 0   | 1   | 1   | 0   | 0   | 1   | 1 | 1 | 1 |
|   |    |    |    |    | #6 | 0  | 1  | 0   | 1   | 0   | 1   | 0   | 1   | 0   | 1   | 0   | 1   | 0   | 1   | 0   | 1 | 0 | 1 |
| #1  | #2 | #3 | #4 | #5 |    |    |    |     |     |     |     |     |     |     |     |     |     |     |     |     |   |   |   |
| 0   | 0  | 0  | 0  | 0  | 32 | 64 | 96 | 128 | 160 | 192 | 224 | 256 | 288 | 320 | 352 | 384 | 416 | 448 | 480 |     |   |   |   |
| 1   | 0  | 0  | 0  | 0  | 1  | 33 | 65 | 97  | 129 | 161 | 193 | 225 | 257 | 289 | 321 | 353 | 385 | 417 | 449 | 481 |   |   |   |
| 0   | 1  | 0  | 0  | 0  | 2  | 34 | 66 | 98  | 130 | 162 | 194 | 226 | 258 | 290 | 322 | 354 | 386 | 418 | 450 | 482 |   |   |   |
| 1   | 1  | 0  | 0  | 0  | 3  | 35 | 67 | 99  | 131 | 163 | 195 | 227 | 259 | 291 | 323 | 355 | 387 | 419 | 451 | 483 |   |   |   |
| 0   | 0  | 1  | 0  | 0  | 4  | 36 | 68 | 100 | 132 | 164 | 196 | 228 | 260 | 292 | 324 | 356 | 388 | 420 | 452 | 484 |   |   |   |
| 1   | 0  | 1  | 0  | 0  | 5  | 37 | 69 | 101 | 133 | 165 | 197 | 229 | 261 | 293 | 325 | 357 | 389 | 421 | 453 | 485 |   |   |   |
| 0   | 1  | 1  | 0  | 0  | 6  | 38 | 70 | 102 | 134 | 166 | 198 | 230 | 262 | 294 | 326 | 358 | 390 | 422 | 454 | 486 |   |   |   |
| 1   | 1  | 1  | 0  | 0  | 7  | 39 | 71 | 103 | 135 | 167 | 199 | 231 | 263 | 295 | 327 | 359 | 391 | 423 | 455 | 487 |   |   |   |
| 0   | 0  | 0  | 1  | 0  | 8  | 40 | 72 | 104 | 136 | 168 | 200 | 232 | 264 | 296 | 328 | 360 | 392 | 424 | 456 | 488 |   |   |   |
| 1   | 0  | 0  | 1  | 0  | 9  | 41 | 73 | 105 | 137 | 169 | 201 | 233 | 265 | 297 | 329 | 361 | 393 | 425 | 457 | 489 |   |   |   |
| 0   | 1  | 0  | 1  | 0  | 10 | 42 | 74 | 106 | 138 | 170 | 202 | 234 | 266 | 298 | 330 | 362 | 394 | 426 | 458 | 490 |   |   |   |
| 1   | 1  | 0  | 1  | 0  | 11 | 43 | 75 | 107 | 139 | 171 | 203 | 235 | 267 | 299 | 331 | 363 | 395 | 427 | 459 | 491 |   |   |   |
| 0   | 0  | 1  | 1  | 0  | 12 | 44 | 76 | 108 | 140 | 172 | 204 | 236 | 268 | 300 | 332 | 364 | 396 | 428 | 460 | 492 |   |   |   |
| 1   | 0  | 1  | 1  | 0  | 13 | 45 | 77 | 109 | 141 | 173 | 205 | 237 | 269 | 301 | 333 | 365 | 397 | 429 | 461 | 493 |   |   |   |
| 0   | 1  | 1  | 1  | 0  | 14 | 46 | 78 | 110 | 142 | 174 | 206 | 238 | 270 | 302 | 334 | 366 | 398 | 430 | 462 | 494 |   |   |   |
| 1   | 1  | 1  | 1  | 0  | 15 | 47 | 79 | 111 | 143 | 175 | 207 | 239 | 271 | 303 | 335 | 367 | 399 | 431 | 463 | 495 |   |   |   |
| 0   | 0  | 0  | 0  | 1  | 16 | 48 | 80 | 112 | 144 | 176 | 208 | 240 | 272 | 304 | 336 | 368 | 400 | 432 | 464 | 496 |   |   |   |
| 1   | 0  | 0  | 0  | 1  | 17 | 49 | 81 | 113 | 145 | 177 | 209 | 241 | 273 | 305 | 337 | 369 | 401 | 433 | 465 | 497 |   |   |   |
| 0   | 1  | 0  | 0  | 1  | 18 | 50 | 82 | 114 | 146 | 178 | 210 | 242 | 274 | 306 | 338 | 370 | 402 | 434 | 466 | 498 |   |   |   |
| 1   | 1  | 0  | 0  | 1  | 19 | 51 | 83 | 115 | 147 | 179 | 211 | 243 | 275 | 307 | 339 | 371 | 403 | 435 | 467 | 499 |   |   |   |
| 0   | 0  | 1  | 0  | 1  | 20 | 52 | 84 | 116 | 148 | 180 | 212 | 244 | 276 | 308 | 340 | 372 | 404 | 436 | 468 | 500 |   |   |   |
| 1   | 0  | 1  | 0  | 1  | 21 | 53 | 85 | 117 | 149 | 181 | 213 | 245 | 277 | 309 | 341 | 373 | 405 | 437 | 469 | 501 |   |   |   |
| 0   | 1  | 1  | 0  | 1  | 22 | 54 | 86 | 118 | 150 | 182 | 214 | 246 | 278 | 310 | 342 | 374 | 406 | 438 | 470 | 502 |   |   |   |
| 1   | 1  | 1  | 0  | 1  | 23 | 55 | 87 | 119 | 151 | 183 | 215 | 247 | 279 | 311 | 343 | 375 | 407 | 439 | 471 | 503 |   |   |   |
| 0   | 0  | 0  | 1  | 1  | 24 | 56 | 88 | 120 | 152 | 184 | 216 | 248 | 280 | 312 | 344 | 376 | 408 | 440 | 472 | 504 |   |   |   |
| 1   | 0  | 0  | 1  | 1  | 25 | 57 | 89 | 121 | 153 | 185 | 217 | 249 | 281 | 313 | 345 | 377 | 409 | 441 | 473 | 505 |   |   |   |
| 0   | 1  | 0  | 1  | 1  | 26 | 58 | 90 | 122 | 154 | 186 | 218 | 250 | 282 | 314 | 346 | 378 | 410 | 442 | 474 | 506 |   |   |   |
| 1   | 1  | 0  | 1  | 1  | 27 | 59 | 91 | 123 | 155 | 187 | 219 | 251 | 283 | 315 | 347 | 379 | 411 | 443 | 475 | 507 |   |   |   |
| 0   | 0  | 1  | 1  | 1  | 28 | 60 | 92 | 124 | 156 | 188 | 220 | 252 | 284 | 316 | 348 | 380 | 412 | 444 | 476 | 508 |   |   |   |
| 1   | 0  | 1  | 1  | 1  | 29 | 61 | 93 | 125 | 157 | 189 | 221 | 253 | 285 | 317 | 349 | 381 | 413 | 445 | 477 | 509 |   |   |   |
| 0   | 1  | 1  | 1  | 1  | 30 | 62 | 94 | 126 | 158 | 190 | 222 | 254 | 286 | 318 | 350 | 382 | 414 | 446 | 478 | 510 |   |   |   |
| 1   | 1  | 1  | 1  | 1  | 31 | 63 | 95 | 127 | 159 | 191 | 223 | 255 | 287 | 319 | 351 | 383 | 415 | 447 | 479 | 511 |   |   |   |

## Approved fluid types

The following types of Martin fog fluid are approved for use in this machine. Each produces a different effect as described below. Martin supplies high quality fog fluids that are based on ultra-pure deionized water. Use only the following genuine Martin fog fluids. No other fluid is suitable for use.

### **Pro Smoke Super (ZR mix)**

Pro Smoke Super fluid is a high-quality, general purpose fluid that produces a dense white airborne fog with medium dispersal time. Its medium to high index of refraction permits both good atmospheric effects and denser “white-outs”.

### **Pro Smoke High Density (SP mix)**

Pro Smoke High Density fluid generates a high density, white, airborne fog with a very high index of refraction and slow evaporation rate. It is well suited for scenic obscuring, dramatic strobe effects, and “white-outs”.

### **Pro Smoke Studio (DX mix)**

In a studio or theater environment, a lighter, faster dispersing fog is often preferred. Pro-Smoke Studio offers a less dense environment to Pro-Smoke Super and is therefore less likely to interfere with TV camera focusing.

### **i-fog**

i-fog is not only kind to your lights, but is also more economical to use thanks to its incredible long “hang time” characteristics. In environments unaffected by extraction and air-conditioning, i-fog can be expected to last

### **Pro Steam Simulation**

Steam simulation fluid specifically designed for ‘steam’ effects. Creates a white burst, but is fast dispersing.

(In order to optimise the machines temperature setting the dip switch on the rear marked ‘Low Temp’ should be set down to position 1).

### **RUSH Fog Fluid™**

RUSH Fog Fluid™ is a specially formulated water-based fog formula and is recommended for use with applicable Martin fog effect generators. While economical it is perfect for medium-density airborne fog effects with medium hang time and leaves no residue; RUSH Fog Fluid™ is designed as an economy fluid that is suitable for use in nightclubs, bars, stage and outdoor events.

*\*Please note that use of RUSH Fog Fluid™ in a JEM™ series fog machine will produce a less than expected professional quality effect due to the nature of using an entry level fog effect fluid.*



**DANGER!** The fog machine can run safely only on the specific fog fluids it is designed for. Use **ONLY** the Martin fog fluids designated in this manual. **NEVER** use any other type of fluid, or toxic gas may be produced. You will probably also cause damage to the system that is not covered by the product warranty. Do not dilute fog fluid with water or any other liquid. Discard fog fluid if it becomes contaminated.



### Pro Clean Supreme Fluid

Specially designed for optimum performance while providing longevity of the heat exchanger, Pro Clean Supreme is the ultimate cleaning solution for Martin fog and haze effect machines. Applying Pro Clean Supreme fluid on a regular basis reduces clogging and further extends the life of Martin fog and haze machines.

Using Pro Clean Supreme every 200 hours, or once a month (depending on usage), will prolong the life of the heat exchanger in Martin fog and haze machines. Connect Pro Clean Supreme fluid to the fogger or hazer, then allow the unit to heat. When fully ready, activate the machine or remote for approximately 30-45 minutes (use the timer function if available). When completed, replace cleaning fluid with appropriate fluid.

Note: Cleaning procedure should be used if the unit is to be stored for 30 days or more. Ensure there is no fluid in the fluid tube when placing in storage.

## Basic service



Before servicing the fog machine, read and observe all the precautions listed in “Safety information” on page 4. Any service not described in this section must be carried out by a Martin service technician.

### Cleaning

Excessive dust, fog fluid, and dirt build-up will degrade performance and cause overheating and damage to the machine that is not covered by the product warranty. To maintain adequate cooling, dust must be cleaned from the outer casing and air vents of the machine periodically.



Isolate the machine from power and allow to cool completely before cleaning. The fog output nozzle remains hot for up to 10 hours after use.

- Remove dust from the air vents with a soft brush, cotton swab, vacuum, or compressed air.
- Clean fog fluid residues from the fog output of the machine using a damp cloth.
- Clean the outer casing with a damp cloth only.

### Fuse replacement

The main fuse for the fog machine is located on the electronics board inside the unit.



**DANGER!** Disconnect the power supply before removing any covers. Live parts inside!

To replace the fuse, disconnect the power cord from the supply, unscrew the screws holding the rear cover of the unit and remove the cover. The electronics board is located at the back of the unit.

Remove the spent fuse and replace with one of exactly the same size and rating. The fuse type is indicated below. Contact Martin Service if the fuse blows repeatedly.

US Model = 20AT (slow-blow), 125 V

EU Model = 10AT (slow-blow), 250 V

# Troubleshooting

| Problem  | Probable cause(s)                          | Suggested remedy  |
|--|--|---|
| Machine will not produce fog when remote control Fog button pressed  | Machine not at operating temperature       | Wait 10 to 15 minutes   |
|  | Machine not powered up or heaters disabled | Ensure mains power switch on, enable heaters by pressing FOG        |
|  | Output level control set to zero           | Increase setting  |
| Machine continues to produce fog when Fog button is not pressed  | Timer is engaged                           | Disengage the timer by pressing the FOG/TIMER ENGAGE button briefly |
| Machine can be fired from the remote control, but not by DMX controller  | DMX address setting incorrect              | Change DMX address (page 15)  |
|  | Poor connection in DMX line                | Check DMX cables and connections                                    |
| Fog output is weak   | Machine requires priming                   | Prime machine (page 10)   |
| Wet, greasy, non-uniform fog output, fluid drips or spits from nozzles, or very loud noise when firing machine | Incompatible fog fluid                     | Use only approved fluids!   |
| Machine appears dead   | Mains fuse blown                           | Replace fuse (page 19)  |
|  | No power at AC cable inlet                 | Check power cable and circuit breaker                               |

## Resetting the machine after fluid out

If the machine runs out of fluid it will automatically shut down to prevent any damage occurring, the Low Fluid LED on the rear will illuminate. To reset simply turn the mains power off and back on again. Refill the fluid container and follow the priming instructions under 'Making fog' on page 10.

# Technical Specifications

## Physical

|                                      |                    |
|--------------------------------------|--------------------|
| Length .....                         | 687 mm (27.1 in.)  |
| Length with optional drip tray ..... | 752 mm (30 in.)    |
| Width .....                          | 379 mm (15 in.)    |
| Height.....                          | 248 mm (9.8 in.)   |
| Height with hanging bracket.....     | 353 mm (13.9 in.)  |
| Weight, dry .....                    | 19 kg (41.9 lb.)   |
| Weight, filled.....                  | 28.5 kg (62.9 lb.) |

## Performance

|                               |   |
|-------------------------------|---|
| Coverage volume .....         | 1200m <sup>3</sup> (42,378 ft <sup>3</sup> ) per minute |
| Fluid consumption (max) ..... | 120 ml/minute   |
| Continuous effect output      |   |
| Ready time .....              | 10 minutes  |

## Control and Programming

|                          |   |
|--------------------------|---|
| Control options .....    | Integrated analog remote control, DMX,<br>..... optional digital remote control, master/slave link mode |
| Control parameters ..... | Continuous or timer-controlled output   |
| Fog .....                | Variable output control, 0-100%   |
| DMX channels .....       | 1   |
| DMX compliance .....     | USITT DMX512-A  |
| RDM compliance .....     | ANSI/ESTA E1.20 RDM   |

## Construction

|                              |   |
|------------------------------|---|
| Color.....                   | Black, silver   |
| Housing.....                 | Steel and aluminium                                   |
| Fluid reservoir .....        | 9.5 l drop-in   |
| Heat exchanger.....          | 1800 W, thermally protected                           |
| Fluid pump .....             | Oscillating piston, high pressure                     |
| Fluid management .....       | Fluid out sensing, sealed for transportation          |
| External fluid control ..... | Fluid sensing   |
| Drip tray.....               | Optional bolt-on tray with reusable collection sponge |

## Installation

|                               |                               |
|-------------------------------|-------------------------------|
| Mounting .....                | Standing or hanging           |
| Orientation.....              | Up to +/- 45° from horizontal |
| Clearance around machine..... | 100 mm (4 in.)                |

## Connections

|                            |                          |
|----------------------------|--------------------------|
| AC power .....             | Neutrik PowerCon         |
| DMX, link mode in/out..... | 3- and 5-pin locking XLR |
| Remote control.....        | 3-pin locking XLR        |
| Firmware .....             | AVR Socket               |

## Electrical

|                                      |                         |
|--------------------------------------|-------------------------|
| AC power (EU) .....                  | 220-240V, 50/60Hz       |
| AC power (US) .....                  | 100-130V, 50/60Hz       |
| Main fuse (EU) .....                 | 10AT (slow-blow), 250 V |
| Main fuse (US) .....                 | 20AT (slow-blow), 125 V |
| Typical power and current (EU) ..... | 1890 W, 8.3 A*          |
| Typical power and current (US) ..... | 1890 W, 14.6 A*         |

*\*Measurements made at nominal voltage. Allow for a deviation of +/- 10%*

## Thermal

Exterior surface temperature, steady state ..... 50° C (122 °F)  
Maximum ambient temperature (Ta max) ..... 40° C (104° F)  
Maximum nozzle temperature ..... 200° C (392° F)  
Minimum ambient temperature (Ta min) ..... 5° C (41 °F)

## Approvals

### EU Model

EU safety: ..... EN 60 335-1+A15, EN 62233  
EU EMC: ..... EN 61000-6-3  
EU immunity: ..... EN 61000-6-1  
Australia/NZ (pending): ..... RCM

### US Model

US Safety ..... UL 998  
Canadian Safety ..... CSA C22.2 No. 104.01



## Included Items

Analog remote control ..... P/N 92765038  
Fluid reservoir, 9.5 l ..... P/N 34300528  
Power input cable, EU, Neutrik PowerCON, stripped ends, 2.5 m (8.2 ft.)  
..... P/N 11501041  
Power input cable, US, Neutrik PowerCON, molded NEMA 5-15P, 2.5 m (8.2 ft.)  
..... P/N 11501042  
User manual ..... P/N 35010032

## Accessories

JEM™ ZR44 Digital Remote Control ..... P/N 92765037  
JEM™ ZR44 Ducting Kit with 5 m (16.4 ft.) ducting ..... P/N 92625005  
JEM™ ZR44 Drip Tray ..... P/N 92620011

### Approved Fluids

JEM™ Pro Smoke Studio  
JEM™ Pro Smoke Super  
JEM™ Pro Smoke High Density  
JEM™ i-fog Fluid  
JEM™ Pro Steam Simulation Fluid  
JEM™ Pro Clean Supreme Fluid

*\*Various sizes available - contact your dealer or see martin.com for more details.*

### Installation Hardware

Half-coupler clamp ..... P/N 91602005  
G-clamp (vertical hanging suspension only) ..... P/N 91602003  
Quick trigger clamp (vertical hanging suspension only) ..... P/N 91602007

### Service Tools

Epsilon 5 AVR Programmer ..... P/N 50502004  
Temperature Calibration Box ..... P/N 92620005

## Ordering information

JEM™ ZR44 Hi-Mass™, EU ..... P/N 92215300  
JEM™ ZR44 Hi-Mass™, US ..... P/N 92215310

*Specifications subject to change without notice. For the latest technical specifications, see [www.martin.com](http://www.martin.com)*



# Notes





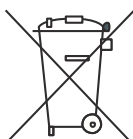

#### **Disposing of this product**

Martin™ products are supplied in compliance with Directive 2002/96/EC of the European Parliament and of the Council of the European Union on WEEE (Waste Electrical and Electronic Equipment), as amended by Directive 2003/108/EC, where applicable.

Help preserve the environment! Ensure that this product is recycled at the end of its life. Your supplier can give details of local arrangements for the disposal of Martin products.





Martin Professional A/S, Olof Palmes Allé 18, DK-8200, Aarhus N  
Phone: +45 87 40 00 00 Internet: [www.martin.com](http://www.martin.com)